

# MixedMode

## CIRCUIT SIMULATION FOR ADVANCED 2D DEVICES

MixedMode is a circuit simulator that includes physically-based devices in addition to compact analytical models. Physically-based devices are used when accurate compact models do not exist, or when devices that play a critical role must be simulated with very high accuracy. The physically-based devices may be simulated using any combination of ATLAS 2D modules. The physically-based devices are placed along side a circuit description that conforms to SPICE netlist format. The applications of MixedMode include power circuits, high performance digital circuits, precision analog circuits, high-frequency circuits, thin film transistor circuits, and optoelectronic circuits.

### Power Circuits

Compact analytical models for high power devices are generally unavailable. MixedMode simulates high power circuits including a variety of devices such as diode, bipolar, thyristor, GTO, MOS and IGBT devices.

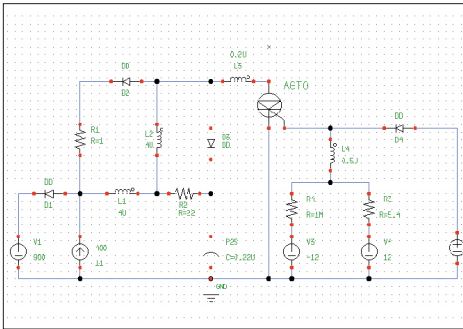

This circuit is used to investigate GTO turn-off. The GTO is a physically-based device whereas compact analytical models are used for the four diodes.

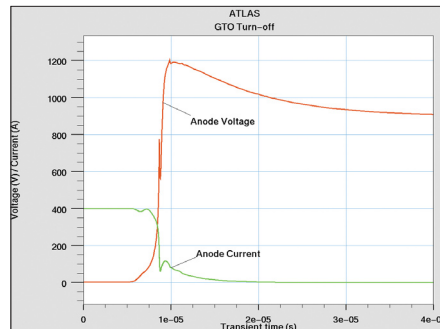

The calculated anode current and anode voltage during turn-off.

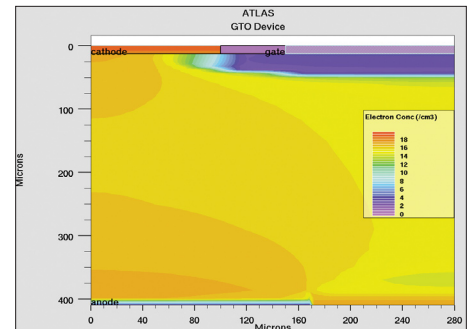

The carrier concentration within the physically-based device can be examined at any time during the circuit transient.

### High Performance Digital Circuits

High performance digital circuits can be simulated using physically-based devices. MixedMode provide accurate descriptions of charge storage and transit time effects.

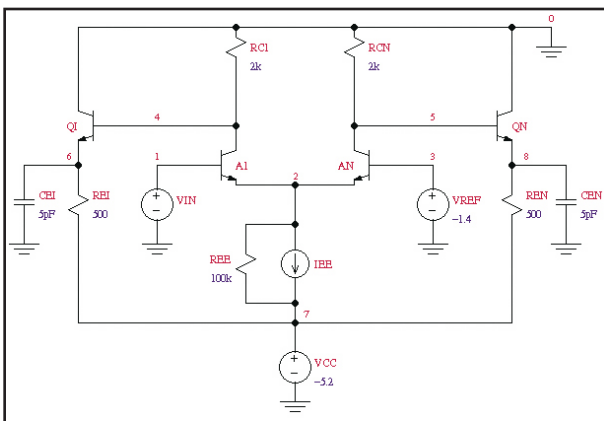

This circuit is an ECL inverter. Transistors AI and AN are simulated as physically-based devices, and transistors QI and QN are simulated using compact analytical models. The calculated base and collector waveforms of the devices are shown in the adjacent figure.

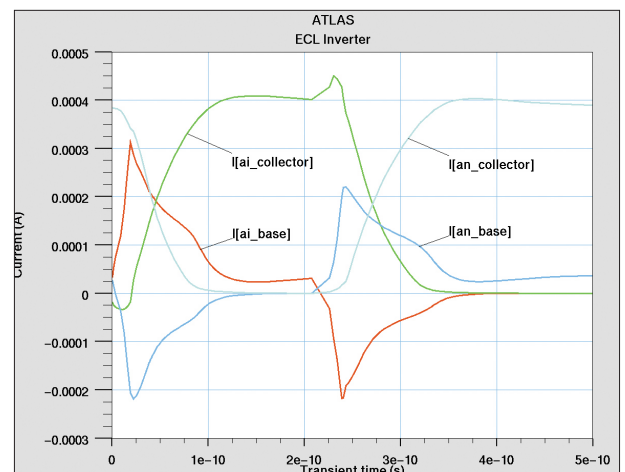

## Precision Analog Circuits

The algorithms used in ATLAS device simulators provide complete charge conservation. MixedMode is therefore able to simulate precision analog circuits.

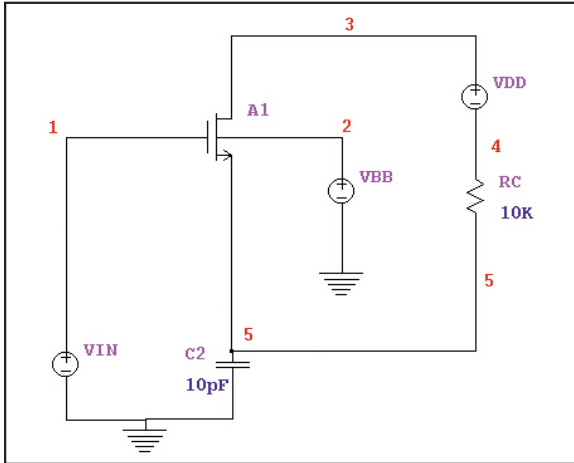

This charge pump circuit provides a standard test of the ability of a device model to conserve charge. The circuit is simulated using MixedMode, with transistor A1 simulated as a physically-based device.

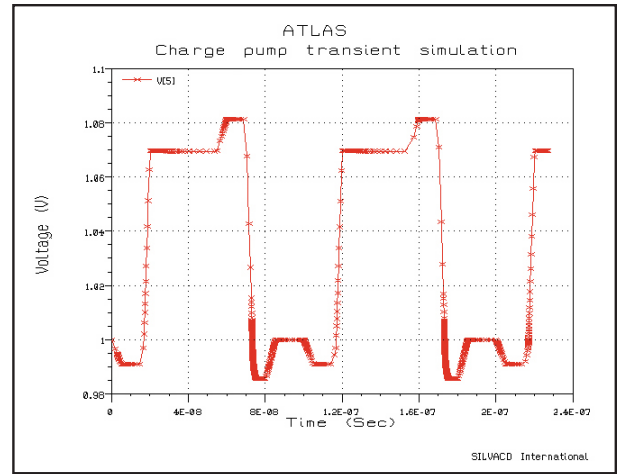

The voltage waveform on the source of the MOS transistor (node 5) has a steady DC level. This demonstrates that charge is conserved.

## Loaded Logic Circuits

MixedMode makes it easy to simulate physically-based devices with realistic circuit loads. One application is determining Inverter switching speeds including the effects of parasitics and fan-out.

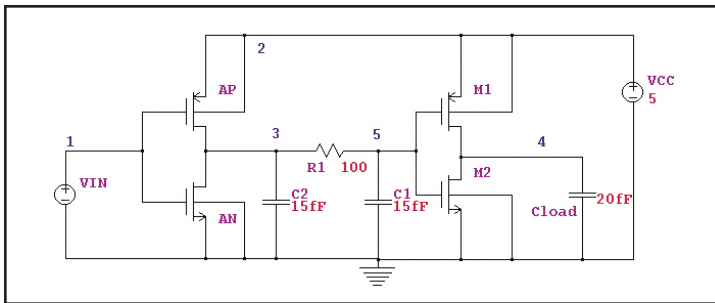

The circuit above shows a CMOS inverter loaded by interconnect parasitics and another inverter. Transistors AP and AN are simulated using physically-based devices and transistors M1 and M2 are simulated using compact analytical models.

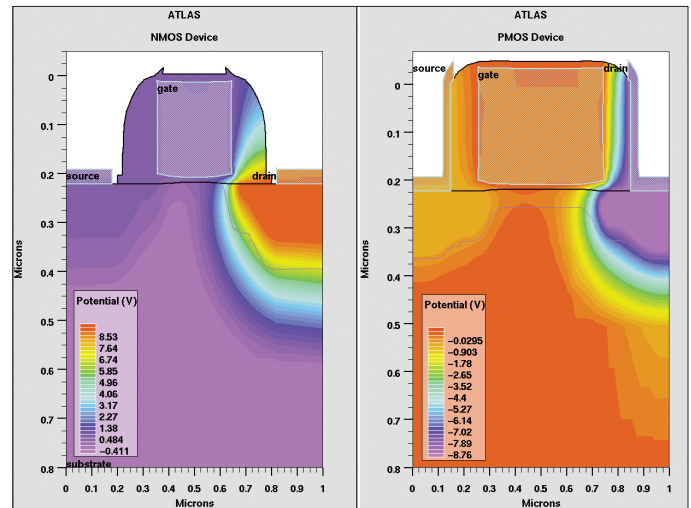

Conditions inside the two physically-based devices. The conditions inside multiple physically-based devices can be displayed simultaneously. Animation showing the evolution of internal conditions is easily generated.

## Technical Specifications

MixedMode circuits can include up to 200 nodes, 300 elements, and up to 10 physically-based ATLAS devices. The circuits are specified using the SPICE input language. MixedMode utilizes the SmartSpice Analog Circuit Simulator model library to provide an accurate and comprehensive description of the circuit elements. A wide range of SPICE models are available including: voltage, current and optical sources, MOSFET(level1,2,3, BSIM3v3, BSIM4, EKV, PSP, HiSIM2, HiSIM\_HV, Silvaco HV MOS), Bipolar(Gummel Poon, VBIC, Mextram, HICUM), HBT, TFT(RPI a-Si, RPI poly-Si, UOTFT), Diode, JFET, MESFET(Curtice, TriQuint), HiSIM-IGBT.

# SILVACO

### HEADQUARTERS

4701 Patrick Henry Drive, Bldg. 2

Santa Clara, CA 95054 USA

Phone: 408-654-4309

Fax: 408-496-6080

JAPAN [jpsales@silvaco.com](mailto:jpsales@silvaco.com)

EUROPE [eusales@silvaco.com](mailto:eusales@silvaco.com)

KOREA [krsales@silvaco.com](mailto:krsales@silvaco.com)

TAIWAN [twsales@silvaco.com](mailto:twsales@silvaco.com)

SINGAPORE [sgsales@silvaco.com](mailto:sgsales@silvaco.com)

CALIFORNIA [sales@silvaco.com](mailto:sales@silvaco.com)

408-567-1000

MASSACHUSETTS [masales@silvaco.com](mailto:masales@silvaco.com)

978-323-7901

TEXAS [txsales@silvaco.com](mailto:txsales@silvaco.com)

512-418-2929

ARIZONA [azsales@silvaco.com](mailto:azsales@silvaco.com)

480-947-2900

[WWW.SILVACO.COM](http://WWW.SILVACO.COM)